



PDH-Pro.com

## Bridge Design - Steel Plate Girders

**Course Number:** CE-02-407

**PDH:** 9

**Approved for:** AK, AL, AR, DE, FL, GA, IA, ID, IL, IN, KS, KY, LA, MD, ME, MI, MN, MO, MS, MT, NC, ND, NE, NH, NJ, NM, NV, NY, OH, OK, OR, PA, SC, SD, TN, TX, UT, VA, VT, WI, WV, and WY

### State Board Approvals

Florida Provider # 0009553 License #868

Indiana Continuing Education Provider #CE21800088

Maryland Approved Provider of Continuing Professional Competency

New Jersey Professional Competency Approval #24GP00025600

North Carolina Approved Sponsor #S-0695

NYSED Sponsor #274

### How Our Written Courses Work

This document is the course text. You may review this material at your leisure before or after you purchase the course.

After the course has been purchased, review the technical material and then complete the quiz at your convenience.

A Certificate of Completion is available once you pass the exam (70% or greater).

If a passing grade is not obtained, you may take the quiz as many times as necessary until a passing grade is obtained).

If you have any questions or technical difficulties, please call (508) 298-4787 or email us at [admin@PDH Pro.com](mailto:admin@PDH Pro.com).



## Module 1: Steel Plate Girders

### Learning Objectives

By the end of this section, you will be able to:

- **Evaluate** span and framing configurations to optimize the structural efficiency of steel plate girder bridges.
- **Calculate** section proportions for webs and flanges in accordance with AASHTO LRFD specifications.
- **Determine** factored moments, shears, and support forces for strength, service, and fatigue limit states.

*Executive Summary:* Steel I-sections represent the most effective solid section for resisting bending and shear in short to medium span bridges. Successful design requires a rigorous application of composite action principles, balancing structural steel grades (typically ASTM A 709) with concrete deck slab properties. Professionals must meticulously manage span arrangements, girder spacing, and limit state requirements—including strength, serviceability, fatigue, and constructibility—to ensure long-term structural integrity and economic viability.

### Introduction

Girder bridges are structurally the simplest and most commonly used for short to medium spans. Steel I-sections are highly effective for resisting bending and shear. This module focuses on straight composite steel-concrete plate girder bridges, presenting design considerations for span arrangement, framing, and section proportioning.



**Figure 1.1-1:** Central Viaduct in San Francisco

## Structural Materials

### Structural Steel

Commonly used structural steels include **ASTM A 709** or **AASHTO M 270** (Grades 36, 50, 50S, 50W, HPS 50W, HPS 70W, and 100/100W).

### Concrete

Concrete with a 28-day compressive strength of  $f'_c = 3.6$  ksi is standard for deck slab construction.

 **Calculation Note:** For normal weight concrete ( $f'_c = 3.6$  ksi), use a modular ratio  $n = \frac{E}{E_c} = 8$

### Modular Ratio Application

- **n:** Used for transient loads applied to short-term composite sections.
- **3n:** Used for permanent loads applied to long-term composite sections (to account for concrete creep).

## Span and Framing Arrangement

### Span Configuration

Optimizing span arrangement is critical for cost-effectiveness.

- **Preferences:** Three- and four-span continuous systems are preferred over two-span systems due to lower negative moments.
- **Efficiency:** End span lengths should be approximately **70% to 80%** of interior span lengths.
- **Constraint:** Avoid configurations that result in uplift due to live load plus impact.

### Girder Spacing

- **Economic Range:** 11 ft. to 14 ft.
- **Short Spans (< 140 ft.):** 10 ft. to 12 ft. preferred.
- **Long Spans (> 140 ft.):** 11 ft. to 14 ft. recommended.
- **Metal Deck Forms:** Limit spacing to approximately 16 ft.

### Diaphragms and Cross Frames

Intermediate cross frames provide bracing against **lateral torsional buckling** during erection and concrete placement. End cross frames transmit lateral wind and seismic loads to the bearings.

## Spacing and Orientation

- **Traditional Limit:** 25 ft. (AASHTO Standard).
- **Modern LRFD:** Requires **rational analysis** for all construction stages and final conditions.
- **Skewed Bridges:** Place parallel to skew up to 20 degrees; normal to girders for skews > 20 degrees.

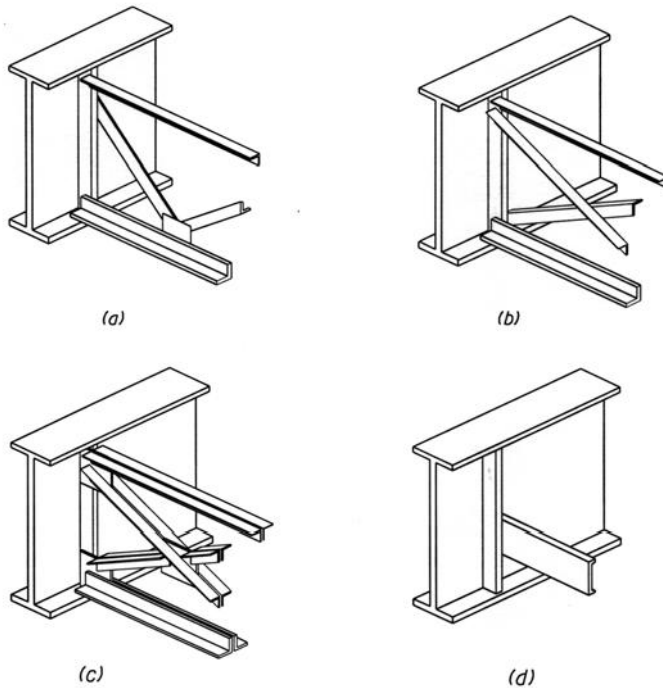

**Figure 1.3-1:** Typical Diaphragms and Cross Frames

**⚠ Safety Constraint:** Diaphragms/cross frames must be as deep as practicable. They shall be at least **0.5** of the beam depth for rolled beams and **0.75** of the girder depth for plate girders.

## Lateral Bracing

Avoid bottom chord lateral bracing if possible, as it creates **fatigue-sensitive details**. Instead, size flanges sufficiently to preclude the need for extra bracing.

## Field Splice Locations

Locate splices near points of **dead load contraflexure** and section changes. Spacing should exceed 50 ft.

- **Shipping limits:** Length < 125 ft.; Weight < 40 tons.
- **Method:** Field splices should always be **bolted**. Welded field splices are prohibited.

## Section Proportion

### Depth to Span Ratios

Standard minimum ratios for the steel portion:

- **Simply Supported:** 0.033
- **Continuous:** 0.027

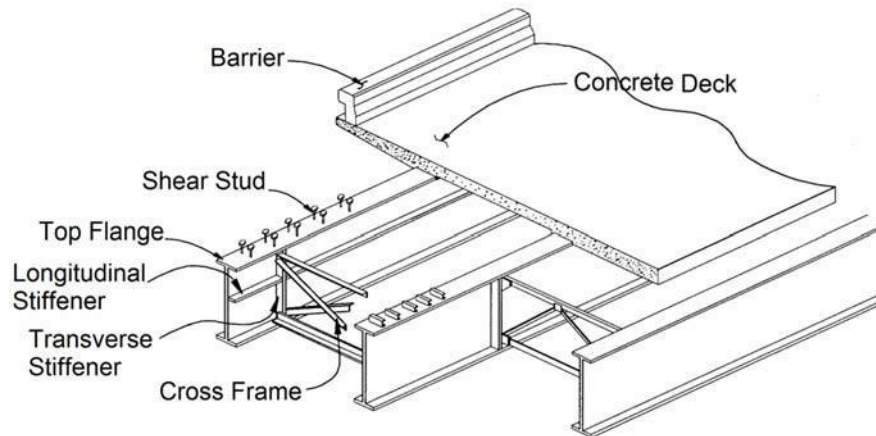

**Figure 1.4-1:** Components of Typical I-Girder Bridge

## Webs

Webs primarily provide shear strength. To prevent distortion from welding, web thickness should not be less than **0.5 inch**.

⚠ **Safety Constraint:** Maintain the following depth-to-thickness ratios ( $\frac{D}{t_w}$ ):

- **Without Longitudinal Stiffeners:**  $\frac{D}{t_w} \leq 150$
- **With Longitudinal Stiffeners:**  $\frac{D}{t_w} \leq 300$

## Flanges

Flanges provide bending strength and should be at least **12 inches** wide.

💡 **Design Tip:** Maintain constant flange width throughout the girder length and change thickness instead of width at splices to optimize fabrication.

### Proportion Limits (AASHTO 6.10.2.2)

1.  $\frac{b_f}{2t_f} \leq 12$
2.  $b_f \geq \frac{D}{6}$
3.  $t_f \geq 1.1t_w$
4.  $0.1 \leq \frac{I_{yc}}{I_{yt}} \leq 10$

#### Where:

- **bf** = Full width of flange (in)
- **tf** = Thickness of flange (in)
- **tw** = Web thickness (in)
- **D** = Web depth (in)
- **I<sub>yc</sub>** = Moment of inertia of compression flange about vertical axis (in<sup>4</sup>)
- **I<sub>yt</sub>** = Moment of inertia of tension flange about vertical axis (in<sup>4</sup>)

### Structural Modeling and Analysis

Girders are typically modeled as beam elements. Stiffness assumptions:

- **Non-composite:** Steel section only.
- **Long-term composite:** 3n properties for permanent loads.
- **Short-term composite:** n properties for transient loads.

### Design Limit States

Design must satisfy:

- **Strength I/II:** Ultimate load capacity.
- **Service II:** Control of elastic/permanent deflections.
- **Fatigue I/II:** Resistance to crack initiation.
- **Constructibility:** Stability during the bridge build.



Purchase this course to  
see the remainder of  
the technical materials.