



Centrifugal and Positive Displacement Pump Basics

Course Number: ME-02-281

PDH: 3

Approved for: AK, AL, AR, FL, GA, IA, IL, IN, KS, KY, LA, MD, ME, MI, MN, MO, MS, MT, NC, ND, NE, NH, NJ, NM, NV, NY, OH, OK, OR, PA, SC, SD, TN, TX, UT, VA, VT, WI, WV, and WY

State Board Approvals

Florida Provider # 0009553 License #868

Indiana Continuing Education Provider #CE21800088

Maryland Approved Provider of Continuing Professional Competency

New Jersey Professional Competency Approval #24GP00025600

North Carolina Approved Sponsor #S-0695

NYSED Sponsor #274

Course Author: Mathew Holstrom

How Our Written Courses Work

This document is the course text. You may review this material at your leisure before or after you purchase the course.

After the course has been purchased, review the technical material and then complete the quiz at your convenience.

A Certificate of Completion is available once you pass the exam (70% or greater).

If a passing grade is not obtained, you may take the quiz as many times as necessary until a passing grade is obtained).

If you have any questions or technical difficulties, please call (508) 298-4787 or email us at admin@PDH Pro.com.

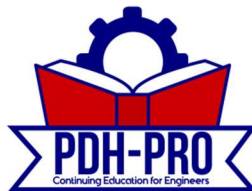



1 Centrifugal Pump Purpose, Construction, and Basic Operation

Learning Objectives

By the end of this section, you will be able to:

1. **Describe** the basic purpose, construction, and operating principle of a centrifugal pump.
2. **Identify** the major components of a centrifugal pump, including the casing, shaft, impeller, volute, diffuser, stuffing box, gland, packing, lantern ring, and wearing rings.
3. **Explain** how an impeller transfers energy to a liquid.
4. **Describe** how a volute and diffuser convert velocity energy into pressure.
5. **Compare** single volute and double volute pump casings.
6. **Classify** impellers as single-suction or double-suction, and as open, semi-open, or enclosed.
7. **Differentiate** radial flow, axial flow, and mixed flow centrifugal pumps.
8. **Explain** why multistage centrifugal pumps are used for high-pressure applications.
9. **Describe** how wearing rings, packing, lantern rings, and mechanical seals support reliable pump operation.

Executive Summary: A centrifugal pump uses a rotating impeller to transfer mechanical energy from a shaft to a liquid. The impeller accelerates the liquid outward, and the pump casing, volute, or diffuser helps convert the liquid's velocity energy into pressure.

Centrifugal pumps are widely used because they can operate over a wide range of flow rates and heads. Their performance and reliability depend on the proper interaction of major components, including the casing, impeller, shaft, volute, diffuser, wearing rings, stuffing box, packing, lantern ring, and mechanical seal.

1.1 Overview of Centrifugal Pumps

Centrifugal pumps are among the most common pumps used in industrial, commercial, utility, and facility operations. They are widely applied because they can move liquids over a broad range of flow rates and discharge pressures. They are used in cooling water systems, process water systems, wastewater systems, chemical systems, boiler feed systems, fire protection systems, and many other applications.

A centrifugal pump is a dynamic pump. It does not trap and push a fixed volume of liquid in the same way as a positive displacement pump. Instead, it adds energy to the liquid by rotating an impeller at high

speed. The impeller gives the liquid velocity. The pump casing then helps convert some of that velocity into pressure.

The basic centrifugal pump consists of:

- A stationary pump casing.
- A rotating shaft.
- An impeller mounted on the shaft.
- A suction connection.
- A discharge connection.
- A volute or diffuser passage.
- A shaft sealing arrangement.
- Replaceable wear components.

The pump casing provides the pressure boundary for the pump. It also directs flow from the suction connection into the impeller and from the impeller toward the discharge connection. The casing normally includes small vents and drains so trapped gases can be removed and the pump can be drained for maintenance.

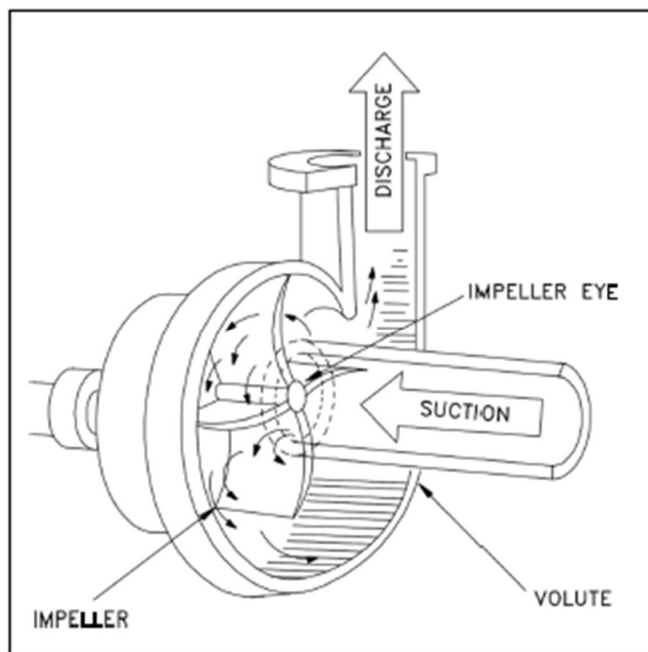

Figure 1. Centrifugal Pump.



1.2 Basic Operating Principle

The operating principle of a centrifugal pump begins at the pump suction. Liquid enters the pump casing through the suction connection and is directed toward the center of the impeller. The center of the impeller is commonly called the **eye** of the impeller.

As the impeller rotates, its vanes impart radial and rotary motion to the liquid. The liquid is forced outward from the eye of the impeller toward the outer edge of the impeller. This outward movement occurs because the rotating impeller transfers mechanical energy from the shaft to the fluid.

The liquid leaving the impeller has high velocity. This high-velocity liquid then enters the volute or diffuser region of the pump casing. The casing passage increases in area, which causes the liquid velocity to decrease. As velocity decreases, part of the velocity energy is converted to static pressure. The liquid then exits through the pump discharge.

This basic energy conversion is the key to centrifugal pump operation:

- The shaft supplies mechanical energy.
- The impeller converts shaft energy into liquid velocity.
- The volute or diffuser converts part of the velocity energy into pressure.
- The discharge connection delivers pressurized flow to the system.

1.3 Pump Casing

The pump casing is the stationary pressure-containing component of the pump. It surrounds the impeller and provides the passageway for liquid entering and leaving the pump.

The casing performs several functions:

- Contains the pressure generated by the pump.
- Directs suction flow to the impeller eye.
- Collects high-velocity liquid leaving the impeller.
- Converts velocity head to static pressure through the volute or diffuser passage.
- Provides mounting surfaces for seals, bearings, and other components.
- Provides locations for vents and drains.
- Protects personnel and equipment from the rotating impeller.

The casing must be strong enough to withstand internal pressure, external pipe loads within allowable limits, operating temperature, and the mechanical stresses associated with pump operation. It must also provide a reliable internal hydraulic shape so that the flow is properly directed.



Centrifugal and Positive Displacement Pump Basics

In many pumps, the casing contains the volute. In other pumps, a diffuser is installed around the impeller to guide the flow before it enters the outer casing passage.

1.4 Impeller

The impeller is the rotating hydraulic component that transfers energy to the liquid. It is mounted on the pump shaft and rotates with the shaft.

The impeller contains vanes. These vanes guide the liquid and increase its velocity. As liquid enters the eye of the impeller, the rotating vanes accelerate the liquid outward toward the periphery of the pump casing. This action creates the flow and head developed by the pump.

The impeller is one of the most important components affecting pump performance. Its diameter, vane shape, width, number of vanes, inlet geometry, outlet geometry, and clearances all affect pump capacity, head, efficiency, and susceptibility to hydraulic problems.

The impeller's purpose can be summarized as follows:

Purpose of the impeller:

The impeller contains rotating vanes that impart radial and rotary motion to the liquid and transfer energy from the rotating shaft to the fluid.

1.5 Volute

The volute is the expanding spiral-shaped region of the pump casing that collects liquid discharged from the outer edge of the impeller.

The volute performs two main functions:

1. It collects high-velocity liquid leaving the impeller.
2. It gradually reduces the liquid velocity by increasing flow area, converting velocity head into static pressure.

As the volute wraps around the impeller, the cross-sectional area increases. This increasing area allows more flow to be collected as the liquid moves around the casing toward the discharge connection. Because the flow area increases, velocity decreases, and pressure increases.

The purpose of the volute can be summarized as follows:

Purpose of the volute:

The volute collects high-velocity liquid from the impeller and gradually reduces flow velocity by increasing flow area, converting velocity head into static head.

Single Volute and Double Volute Casings

Some centrifugal pumps use a single volute. Others use a double volute, sometimes called a split volute. In a double volute pump, the casing is arranged so that two separate volute passages receive liquid from opposite sides of the impeller.

A double volute pump receives liquid from two **180-degree** regions of the impeller. This can help balance the pressure forces around the impeller. In some applications, a double volute reduces radial forces acting on the shaft and bearings. Reducing radial load can improve bearing life, reduce shaft deflection, and improve mechanical reliability.

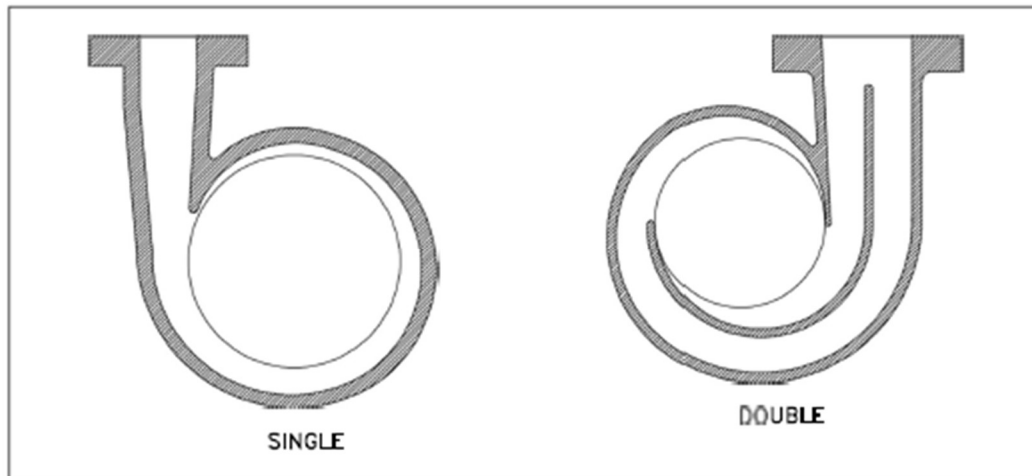

Figure 2. Single and Double Volute.

Table 1-1. Single Volute and Double Volute Comparison

Feature	Single volute pump	Double volute pump
Flow collection	One expanding volute passage	Two volute passages collecting flow from opposite sides
Hydraulic loading	Can create unbalanced radial load, especially away from best efficiency point	Helps reduce radial load on shaft and bearings
Construction	Simpler casing geometry	More complex casing geometry



Purchase this course to
see the remainder of
the technical materials.